

DW Series
DW Office headset

- | | | |
|-------------------|---------------------|--------------------------------|
| EN Quick Guide | NO Snabbguide | JA クイックガイド |
| DE Kurzanleitung | SV Snabbguide | PL Skrócona instrukcja obsługi |
| FR Guide express | NL Mini handleiding | TR Hızlı Kılavuz |
| ES Guía rápida | IT Guida rapida | ZH 快速指南 |
| DA Kvikvejledning | PT Guia Rápido | |

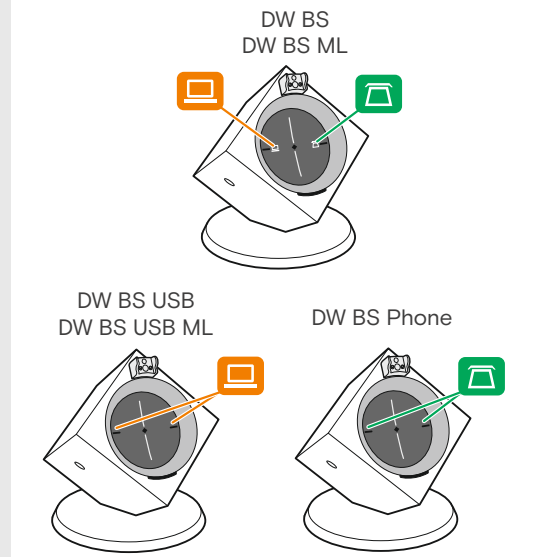
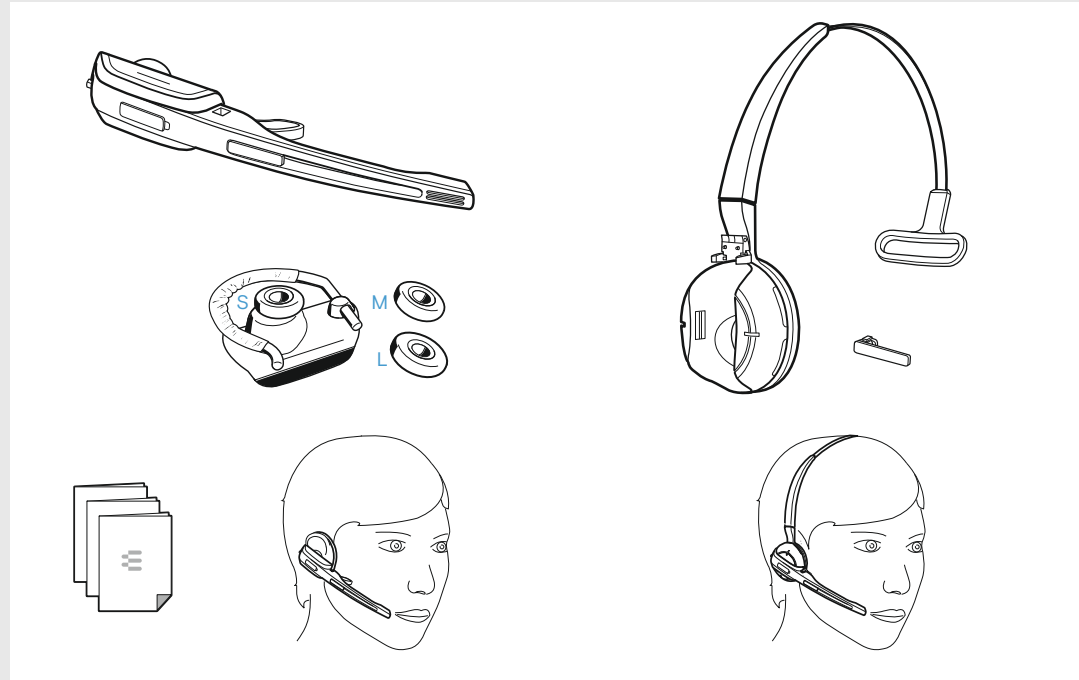

Charging the headset | Headset laden | Charger l'oreillette | Cargar el headset | Opladning af hovedsættet | Ladda headsetet | Lade hodesett | Headset laden | Caricamento dell'headset | Carregar os micro-auscultadores | ヘッドセットを充電する | Ładowanie zestawu słuchawkowego | Kulaklık setinin şarj edilmesi | 给耳机充电

Swapping the direction of the volume buttons | Richtung der Lautstärke-tasten tauschen | Permuter la fonction des touches Volume +/- | Cambiar la asignación de las teclas de volumen | Ændring af funktionen for lystyrkeknappen | Ändra volymknapparnas funktion | Endre tilordning av lydstyrkeknappene | De functie van de volumetoetsen omwisselen | Cambio dell'assegnazione dei tasti del volume | Trocar a ocupação das teclas de volume | 音量ボタンの設定を変更する | Zmiana przyporządkowania przycisków regulacji głośności | Ses seviyesi tuşlarının atamalarının değiştirilmesi | 交换音量按钮的分配

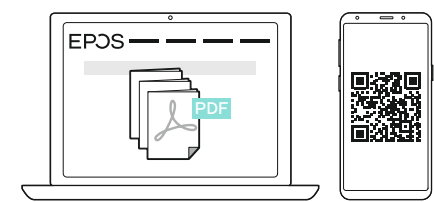
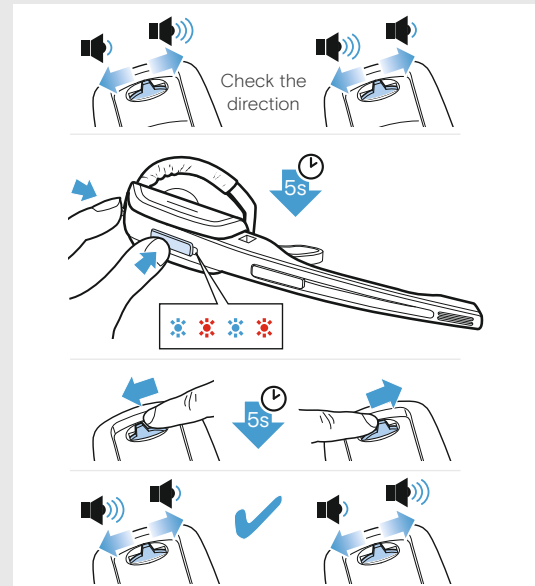
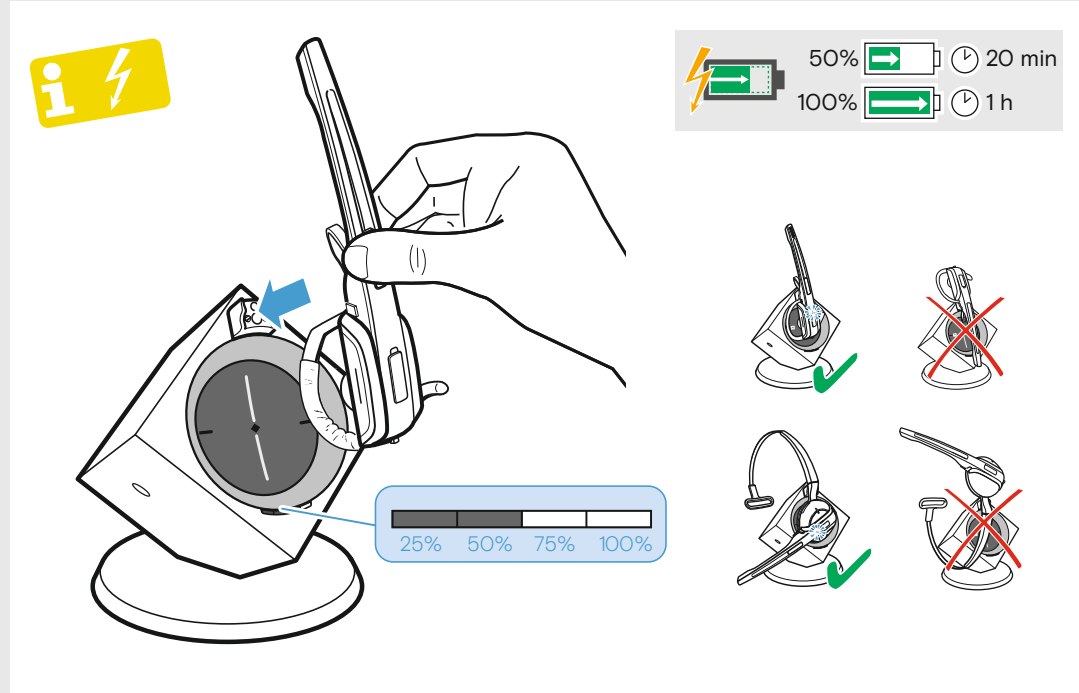

www.eposaudio.com/support

Sennheiser Communications A/S
Industriparken 27, DK-2750 Ballerup, Denmark
www.eposaudio.com

Printed in China, Publ. 11/19, 770-00072/A07

Using the headset | Headset verwenden | Utiliser l'oreillette | Utilizar el headset | Anvendelse af hovedsættet | Använd headsetet | Benytte hodesettet | De headset gebruiken | Utilizzo dell'headset | Utilizar o auricular | ヘッドセットの使用 | Stosowanie zestawu słuchawkowego | Kulaklığın kullanımı | 使用耳机

Making calls via the headset | Über das Headset telefonieren | Téléphoner avec l'oreillette | Telefonar mediante el headset | Opkald via hovedsættet | Ring med headsetet | Ringe ved hjelp av hodesettet | Bellen met behulp van de headset | Telefonare con l'headset | Fazer uma chamada telefónica através do micro-auscultador | ヘッドセットから電話する | Telefonowanie poprzez zestaw słuchawkowy | Kulaklık sesi üzerinden telefon etme | 通过耳机进行电话通话

Connecting the headset and the base station

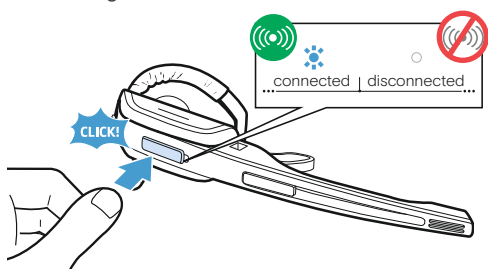

Volume

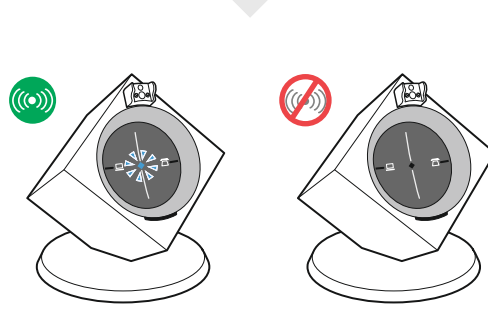
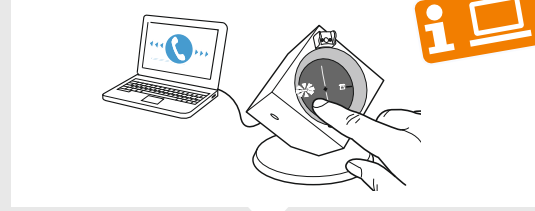
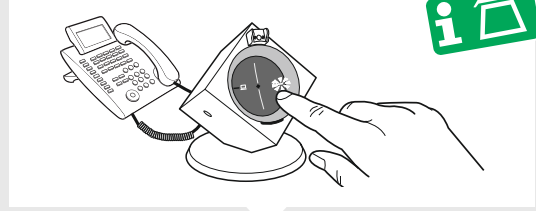
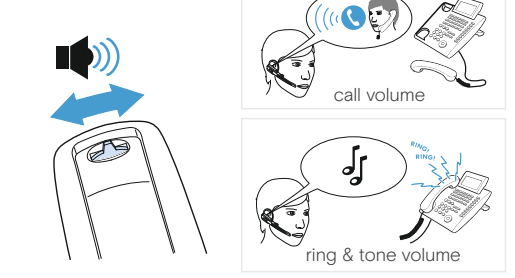

MUTE Mic

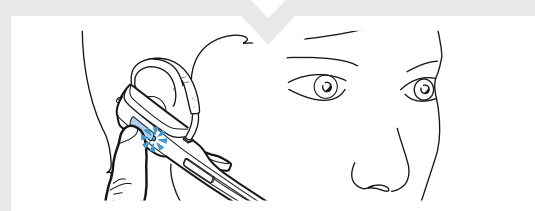
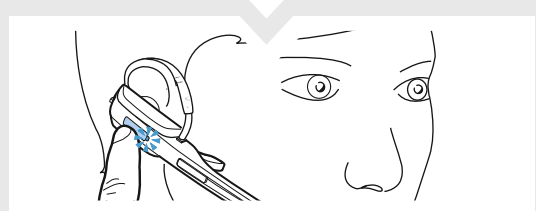
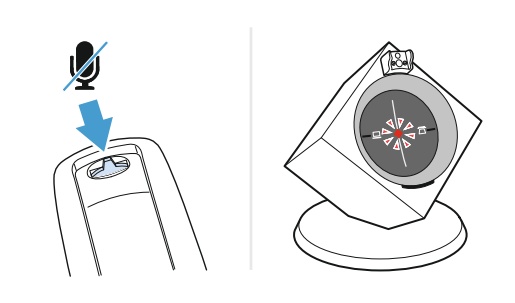

Wearing the headset with the earhook | Headset mit Ohrbügel verwenden | Porter l'oreillette avec le crochet d'oreille | Utilizar el headset con gancho de auricular | Anvendelse af hovedsættet med ørebøjle | Använd headset med öronbygel | Bruk hodesett med ørebøyle | De headset in combinatie met de oorbeugel gebruiken | Utilizzo dell'headset con archetto auricolare | Utilizar o micro-auscultador com haste auricular | ヘッドセットをイヤーフックと一緒に装着する | Stosowanie zestawu słuchawkowego z pałkiem nauszny | Kulaklık setinin kulak bantıyla kullanılması | 利用耳夹使用耳机

Wearing the headset with the headband | Headset mit Kopfbügel verwenden | Porter l'oreillette avec l'arceau | Colocarse el headset con gancho de auricular | Sådan bæres hovedsættet med hovedbøjle | Sätt på headsetet med huvudbygel | Sett på hodesett med hodebøyle | De headset in combinatie met de hoofbeugel gebruiken | Applicazione dell'headset con archetto per testa | Colocar o micro-auscultador com aro de cabeça | ヘッドセットをヘッドバンドと一緒に装着する | Stosowanie zestawu słuchawkowego z pałkiem nagłownym | Kulaklık setinin kafa bantıyla takılması | 利用头戴配戴耳机

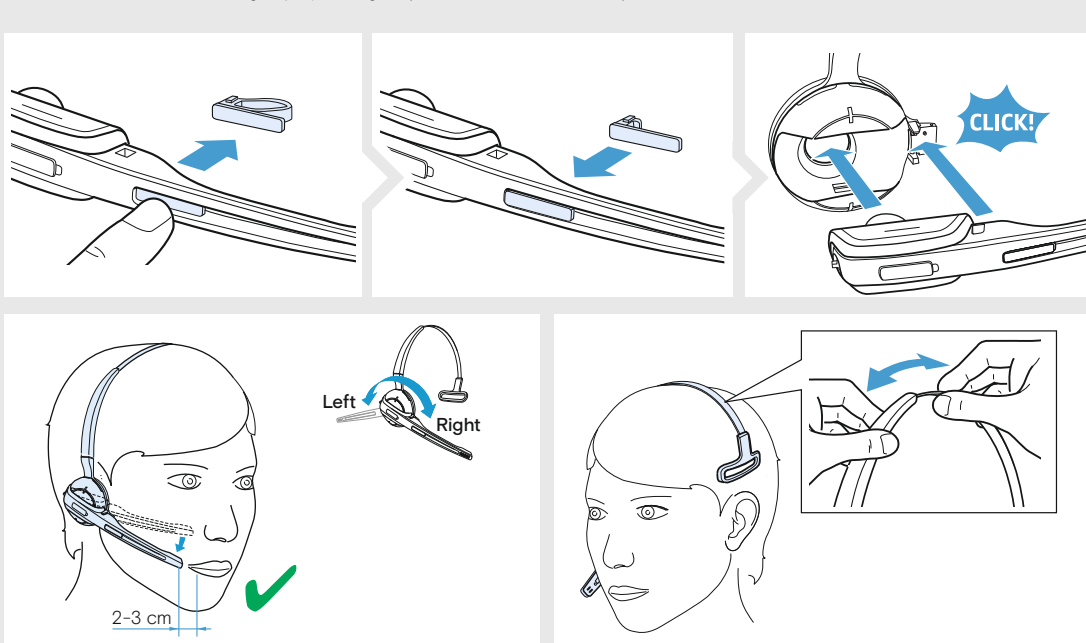
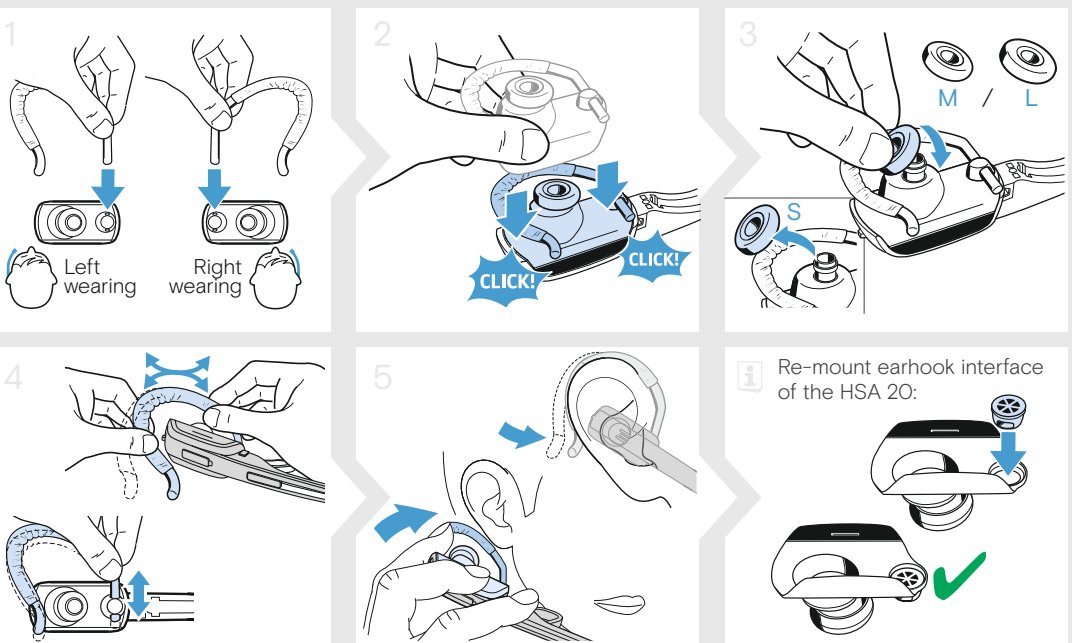

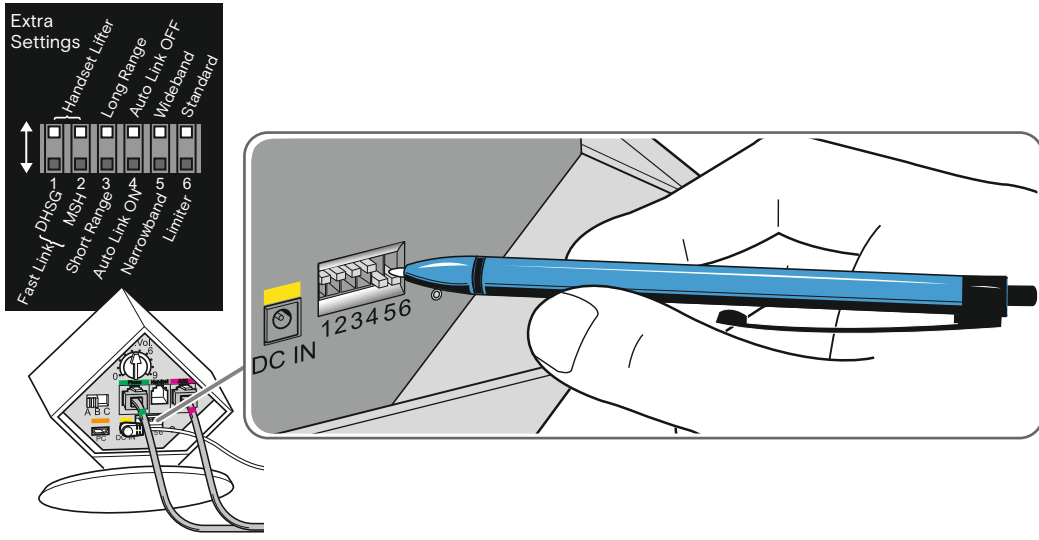

- Manual operation**
Lifts/hangs up the handset manually or using the handset lifter (Sennheiser HSL 10).
- Electronic hook switch (DHSG standard)**
Call control via the headset system. For faster link establishment, see Fast Link.
- Electronic hook switch (MSH standard)**
Call control via the headset system.
- Fast Link for DHSG standard & HSL 10 handset lifter**
Recommended for frequent callers. Fast link establishment without delay due to hidden link to the base station.
- Standard radio range**
- Reduced radio range**
Use this setting in order to avoid interference with other DECT systems. Range of approx. 10 m indoors.
- Manual link establishment**
When taking the headset out of the base station, you have to manually establish the wireless link between headset & base station.
- Automatic link establishment - Auto Link**
When taking the headset out of the base station, a wireless link is automatically established between headset and base station.
- Wideband audio transmission**
Automatic frequency adjustment of wideband & narrowband calls. Wideband audio transmission is e.g. supported by Skype & gives high speech quality. Battery life: 8 hours
- Narrowband audio transmission**
Battery life: 12 hours
- Standard limitation**
- Limited volume (country specific)**
EU and US version: in compliance with Directive 2003/10/EC
AU version: in compliance with Directive AS/ACIF G616:2006

Holding a conference call: Connecting the master headset & the guest headsets with a base station | Telefonkonferenz durchführen: Master-Headset & Guest-Headsets mit einer Basisstation verbinden | Tenir une conférence téléphonique: Connecter l'oreillette maître et l'oreillette invitée à la station de base | Realizar una conferencia telefónica: Conexión del headset maestro y de los headsets invitados con la estación base | Afvikling af en telefonkonference: Etablering af forbindelse mellem master-hovedsæt & gæst-hovedsæt og basisstationen | Telefonkonferens: Anslut masterheadsetet og gæstheadseten till en basstation | Foreta telefonkonferanse: Opprette forbindelsen masterhodesettet og gjestehodesettet skal ha med basestasjonen | Een telefonische conferentie uitvoeren: De master-headset en guest-headsets met een basisstation verbinden | Per eseguire una conferenza telefonica: collegare l'headset principale e l'headset guest con una stazione base | Realizar uma chamada em conferência: Ligar o micro-auscultador mestre e os micro-auscultadores secundários à base | 電話会議を実行する: マスター・ヘッドセットとゲスト・ヘッドセットをベースステーションに接続する | Prowadzenie konferencji telefonicznej: Połączenie zestawu słuchawkowego Master i Guest ze stacją bazową | Telefon konferans: Ana (Master) ve misafir kulaklik setlerinin baz istasyonuna bağlanması | 举行电话会议: 将主耳机和客耳机与基站连接

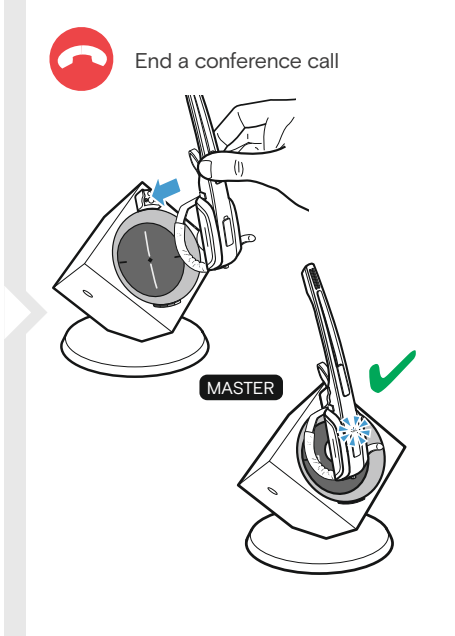
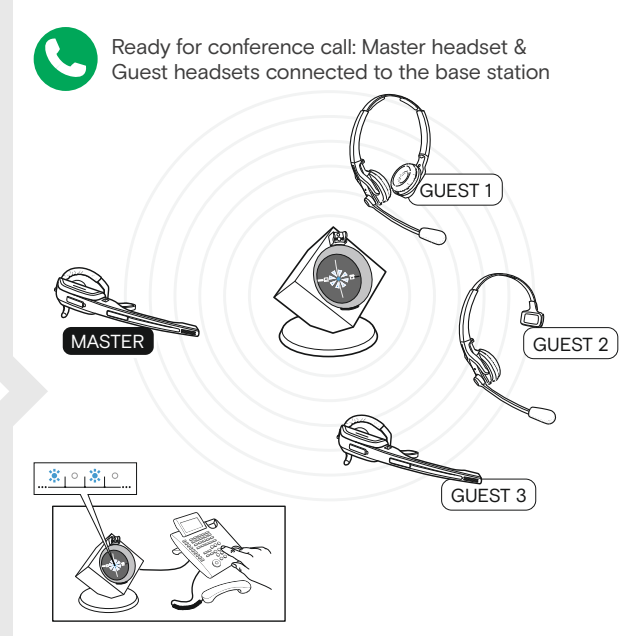
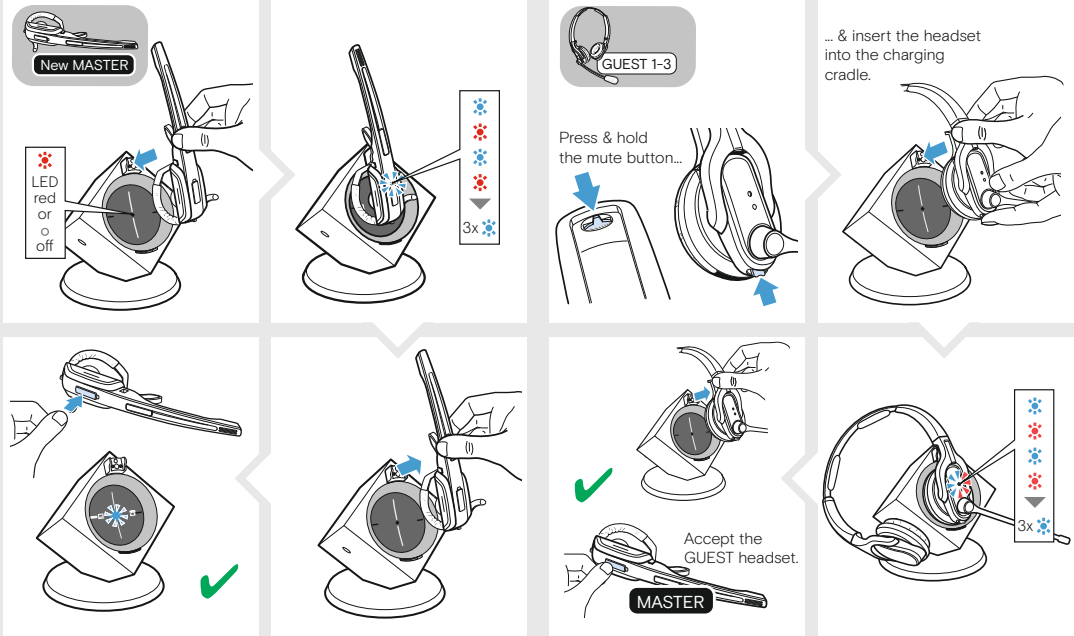

Leaving the DECT range | DECT-Reichweite verlassen | Sortir de la portée DECT | Salir del rango DECT | Sådan forlades DECT-rækkevidden | Lämna DECT-räckvidden | Forlade DECT-rekvidden | De DECT-reikvidde verlaten | Allontanamento dal campo di autonomia DECT | Sair do alcance DECT | DECT通信範囲を離れる | Opuszczanie zasięgu DECT | DECT menzillinden çıkılması | 离开DECT有效范围

Automatic link establishment | Automatischer Verbindungsaufbau | Établissement automatique d'une liaison | Establecimiento de conexión automática | Automatisk forbindelsesopbygning | Automatisk oppkoppling | Automatisk forbindelsesopbygning | Automatische opbouw van de verbinding | Connessione automatica | Ligação automática | 自動接続 | Automatische nawiązanie połączenia | Otomatik bağlantı kurulması | 自动建立连接

Replacing the ear pad | Ohrpolster austauschen | Remplacer le coussinet d'oreille | Cambiar las almohadillas para las orejas | Udskitning af ørepolstringer | Byta öronkuddar | Utskitning av øreputer | De oorkussens vervangen | Sostituzione dei cuscinetti auricolari | Substituir as almofadas | イヤーパッドを交換する | Wymiana poduszek słuchawkowych | Kulak pedinin değiştirilmesi | 更换耳垫

Charging several headsets simultaneously | Mehrere Headsets gleichzeitig laden | Charger plusieurs oreillettes simultanément | Cargar simultáneamente varios headsets | Opladning af flere hovedsæt samtidig | Ladda flera headset samtidigt | Lade flere hodesett samtidig | Meerdere headsets tegelijk opladen | Caricamento simultaneo di più headset | Carregar, simultaneamente, vários micro-auscultadores | 複数のヘッドセットを同時に充電する | Jednoczesne ładowanie kilku zestawów słuchawkowych | Birden çok kulaklik setinin aynı anda şarj edilmesi | 同时给多个耳机充电

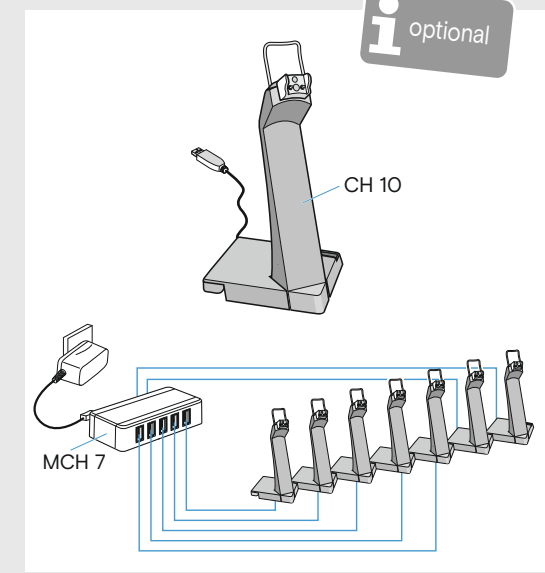
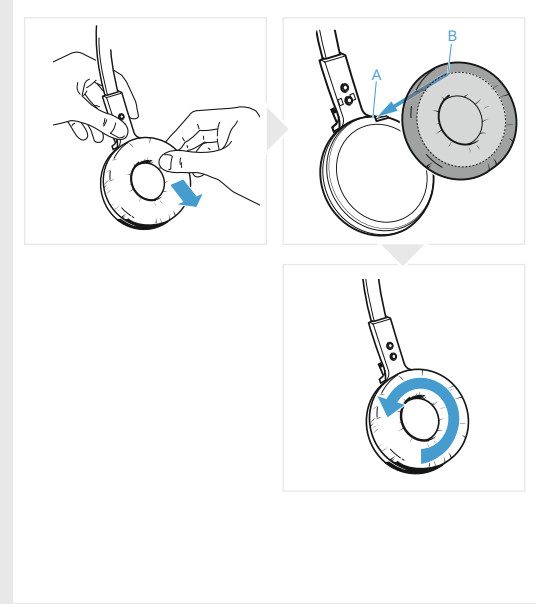
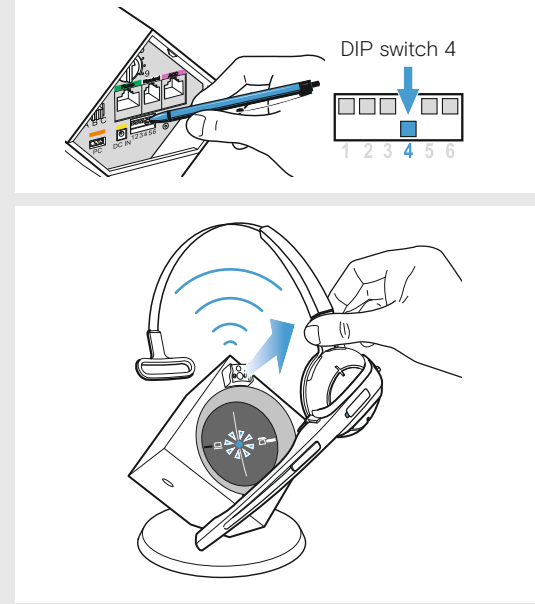
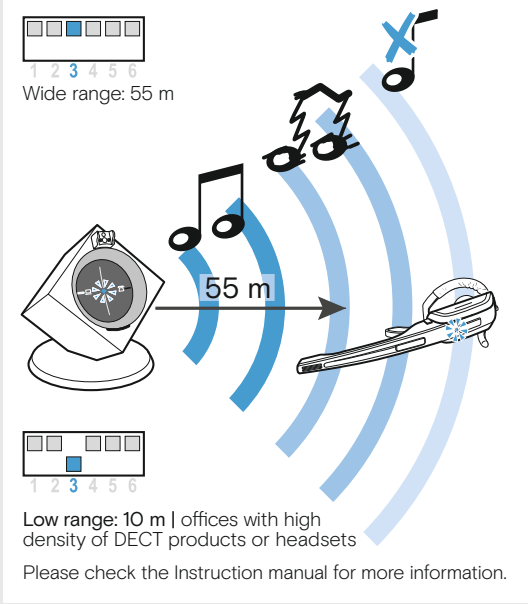

Detailed information / Accessoires | Ausführliche Informationen / Erhältliches Zubehör | Informations détaillées / Accessoires | Información detallada / Accesorios disponibles | Udførlige oplysninger/tilbehør som kan erhverve | Mer information/tilbehør | Detaljert informasjon / tilgjengelig tilbehør | Ultvoerige informacie/verkrijgbare toebehoren | Informazioni dettagliate / accessori disponibili | Informações mais pormenorizadas/Acessório disponível | 詳細なインフォメーション / 使用可能なアクセサリ | Szczegółowe informacje / dostępne akcesoria | Ayrıntılı Bilgiler / Mevcut Aksesuarlar | 详细信息/可供选购的附件

